

The WM-535 Lever Hand Control is designed for demanding off-road applications. It is infinitely variable between 0 and 54 degrees with applicable uses that include engine RPM, chassis module inputs and hydraulic pump control. The Lever Hand Control is environmentally protected, sealed to a rating of IP67 and is highly EMI resistant (SAE J1113). This allows for mounts inside or outside the cab.

The Lever Hand Control unit is equipped with a Hall-effect, non-contact sensor that can be programmed for analog output and/or integrated switches. In addition, the unit can be customized with contact or PWM sensors.

The Lever Hand Control has a molded Nylon 66 body, and features a powder-coated customizable steel lever arm with vinyl knob.



SPECIFICATIONS

PRODUCT LIFE	Full Travel Cycles	800,000
ELECTRONICS	Seal Integrity EMI	Electronics IP67 sealed (IEC 60529) SAE J1113 Compliant
ELECTRICAL	Operating Voltage Output Signal	5V and 12V-24V Dual APS, Dual PWM, APS, PWM, APS/IVS
TRAVEL ANGLE	Degrees Operating Torque	54° 5.3 Nm
MECHANICAL	Max Torque Vibration	60 Nm 8 hour, 3-axis, random broadband up to 11g
ENVIRONMENTAL	Operating Temp Range Storage Temp Range Humidity Sand/Dust	-40°C to 85°C -40°C to 125°C 95% RH for 120 hours, 27°C to 75°C Tested to SAE J1455
MATERIALS	Main Body Knob/Lever Sensor Housing	Nylon 66 Vinyl/Corrosion Resistant Plated Steel PBT Polyester

MECHANICAL DIMENSIONS (mm)

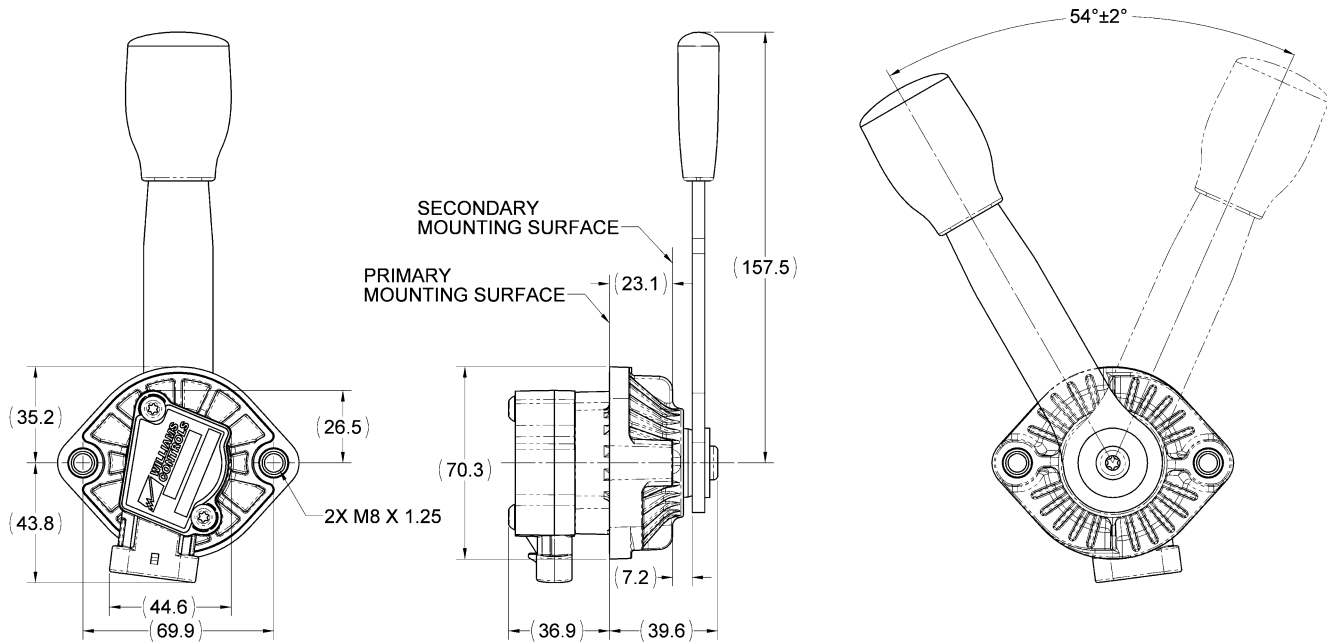

TYPICAL OUTPUT CHARACTERISTICS (other outputs are available)

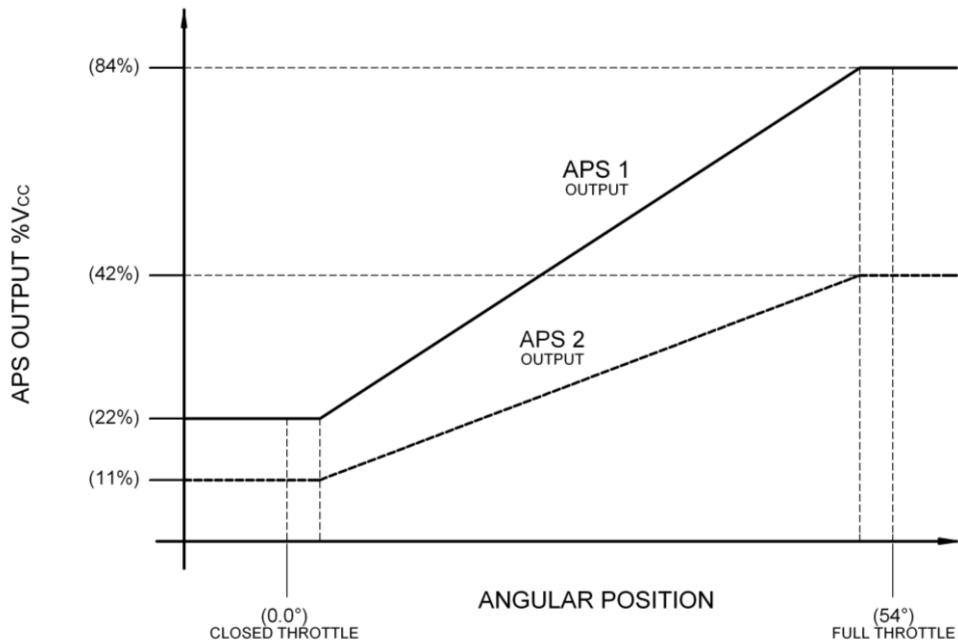

© 2014 Curtiss-Wright. All rights reserved. Specifications are subject to change without notice. All trademarks are property of their respective owners.

WM535-11/14



USA
 Portland
 Oregon
 T: +1.509.684.8600
 F: +1.503.684.3879
 cwig.us@curtisswright.com
 www.cw-industrialgroup.com

Europe
 Christchurch
 United Kingdom
 T: +44.1425.271444
 F: +44.1425.272655
 cwig.uk@curtisswright.com
 www.cw-industrialgroup.com

Asia
 Shanghai
 China
 T: +86.213.3310670
 cwig.cn@curtisswright.com
 www.cw-industrialgroup.com