

VR2

NEW HORIZONS

VERSATILE
WHEELCHAIR
CONTROL
SYSTEM FOR
TODAY'S
ENVIRONMENT

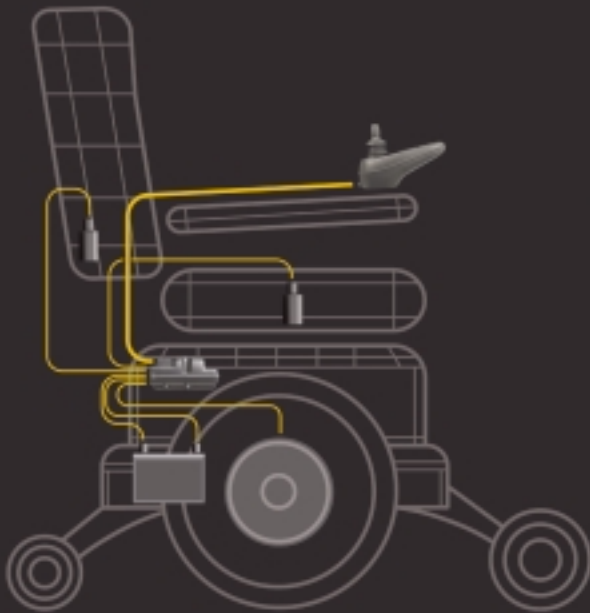



VR2 WHEELCHAIR CONTROL SYSTEM

- Compact Power Module
- Stylish Joystick Module
- Drive plus 1 or 2 actuators
- Flexible and manageable cable
- Easy installation onto all types of wheelchair
- Simple and familiar programming
- TÜV certified, documentation for FDA/CE
- Service-friendly

JOYSTICK MODULE

- Ergonomic and stylish design
- Low force pushbuttons
- Simple and clear displays
- User-friendly speed control
- Up to 5 drive profiles
- Field serviceable components

POWER MODULE

- 60A and 70A versions
- Superior drive control
- High power charger connector
- Versatile inhibit inputs
- Readily available mating connectors

The small, robust

The VR2 sets new standards of performance and value for mainstream wheelchair controllers. The configuration comprises a compact Power Module and an extremely well styled Joystick Module. These are interconnected by a convenient cable, which can be easily routed and secured, and is equally suitable for both powerbase and folding wheelchair models. PGDT's previous series, the VSI controller, set a high precedent but the VR2 beats that performance, as well as introducing many new features. The VR2's power, superb drive control and flexibility of seating adjustment really set new standards of versatility for a controller in this category. Conversion to VR2 is simple and easy; the Joystick Module has the same fixing hole pitch as the VSI, meaning little or no modifications to armrests. Full documentation packages for FDA and CE files are available and the product has TÜV certification.

VR2

VR2 JOYSTICK MODULE

Two versions of the Joystick Module are offered - drive only and drive with seat actuator control. Both versions are ergonomic in their design and stylish in their appearance, enhancing the looks of any wheelchair to which they are fitted. The controls are simple and easy to understand, making it very easy for new wheelchair drivers to become quickly confident. Proven push-button technology has been used for the keypad and high-intensity LEDs for the displays; and there is volume adjustable, audible feedback of all user operations. Via simple programming, the VR2 can be configured to operate with single or multiple drive profiles, up to a maximum of 5. This gives the option to create unique drive performance personalities, which the user can easily select to suit the wheelchair's environment. As has been standard with PGDT for many years, the Joystick Module contains an off-board charging socket and supports a security lock function.



The thin and flexible interconnecting cable is ideal for use on swing-away arm mechanisms. Because the cable is 'pig-tailed' to the Joystick Module, there is no rigid protruding connector that could possibly receive damage.



PG DRIVES TECHNOLOGY

system that's flexible and simple to install with

VR2 POWER MODULE

To offer the optimum combination of power and price, the Power Module comes in two forms - a full 60A model and a full 70A model. These current ratings provide much more than just a short burst of high current, which in turn means that manufacturers can specify heavier load ratings or faster speeds for their wheelchairs. Perhaps the most exciting aspect of the Power Module is its drive control capability. Advances in PGDT's software design have led to a gradient performance never previously available in cost-effective systems. If the wheelchair is driven up a hill, there is practically zero roll-back between the time the joystick is released and the brakes are applied.

To add further value to the system, the Power Module can be populated to drive 1 or 2 seat actuators. Each output channel has a 12A capability and automatic end-stop detection, meaning there is no need to fit expensive and potentially unreliable limit switches.

A high-power connector, primarily intended for an On-Board Charger, is fitted to the Power Module as standard. The 12Arms rating of this connector means it can be safely used for charging even large capacity batteries. A universal inhibit pin is included, which can be set-up for compatibility with any type of charger inhibit output. A second inhibit connection is also provided and can be used wherever there is a need to limit the speed or prevent the drive of the wheelchair. Each of these inhibits can be programmed independently, with each offering four different programmable speed levels depending on the state of the inputs. This unique flexibility is further enhanced by innovative, new actuator interlocking functions, whereby the VR2 can be programmed to lock-out movement of either actuator in either or both directions, in response to switches or potentiometers connected to one or both of the inhibit inputs. This is a level of functionality never previously available, even within very complex control systems.

The entire connection system for the Power Module has been designed not only to the highest standards of reliability, but also with cost and logistics in mind. All mating connectors are reasonably priced and easily available from PGDT UK, PGDT US or our connector partner in Asia.

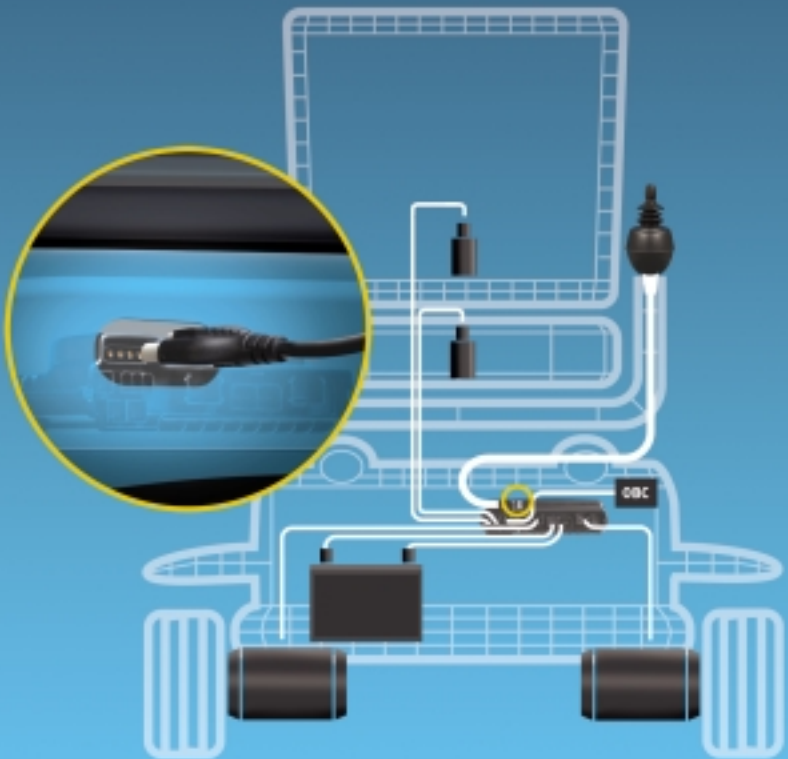
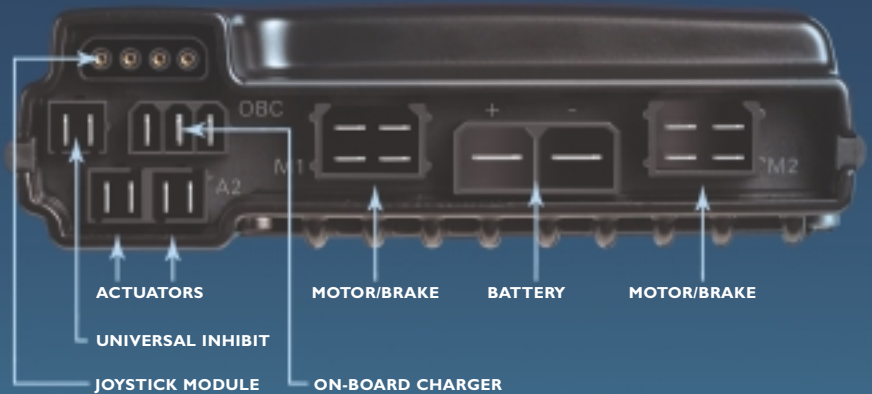

PG DRIVES TECHNOLOGY

cost-effective servicing

PROGRAMMING AND SERVICE

- The VR2 is programmable using either the PPI Handheld Programmer or PGDT's PC Programmer. Both methods provide familiar and user-friendly adjustment of drive performance parameters, making it simple to tune a wheelchair to the preferences of an individual user. The PC Programmer has comprehensive and informative diagnostics help, intended to aid the service professional in effecting timely and correct repairs.

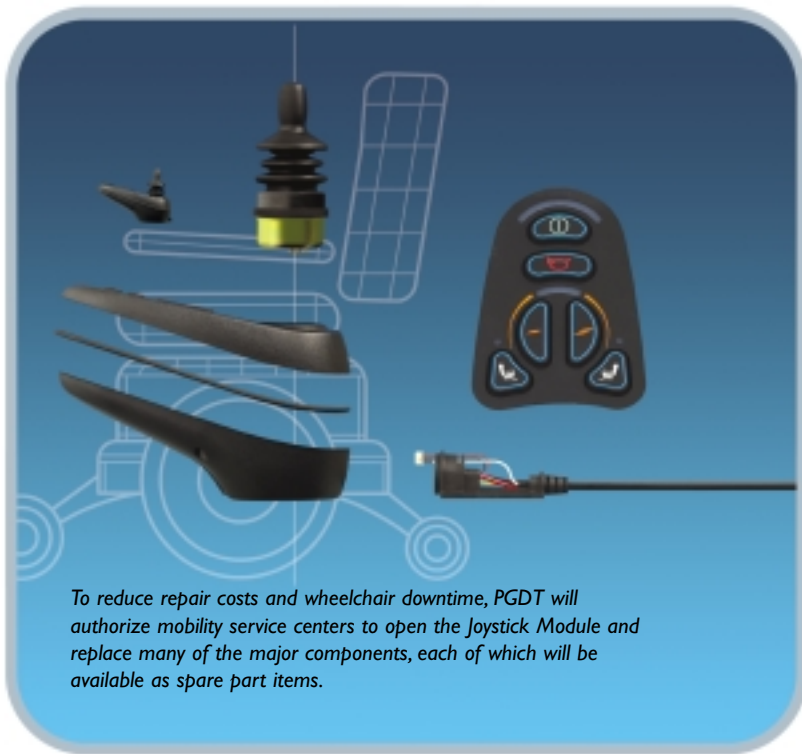

To reduce repair costs and wheelchair downtime, PGDT will authorize mobility service centers to open the Joystick Module and replace many of the major components, each of which will be available as spare part items.



- PGDT's eWarranty is an exciting new scheme, through which a mobility service center can report a suspected defective controller directly to PGDT, via our website. If the controller is within the warranty period and has a genuine defect, then a replacement unit will be promptly dispatched. Part of the submission is to supply programming information; this is then used to program the replacement exactly as the original, meaning the new unit can be fitted without further adjustment. The reporting process also aims to eliminate correctly functioning controllers being returned inadvertently.



Training courses, within North America and Europe, are also available. The standard sessions concentrate on mobility vehicle diagnosis, service and repair; however, custom training can be provided to cover any aspect of PGDT's products and services.

For more information on servicing, eWarranty and training, visit our website pgdt.com

VR2

SPECIFICATIONS

Supply Voltage:	24 Vdc
Operating voltage:	16Vdc to 28Vdc
Peak Voltage:	38Vdc
Reverse battery voltage:	40Vdc
Drive current:	60A
	70A
PWM Frequency:	20kHz
Brake Voltage:	Programmable, 12Vdc or 24Vdc
Brake Current:	1A max. per brake
Battery Charging Current:	12Arms max.
JSM Charger Connector:	Use Neutrik NC3MX
PM Charger Connector:	Use PG D50752
Actuator Current:	12A max.
Moisture Resistance:	IPX4
Safety:	Multiple hardware & software strategy Designed to ISO7176/14
Operating temperature:	-25°C to 50°C
Storage temperature:	-40°C to 65°C
EMC on sample powerchair Susceptibility:	Tested at 30V/m to EN12184 and ANSI/RESNA requirements
Emissions:	To EN55022 class B
ESD:	IEC801 part 2

For further details refer to VR2 Technical ManualSK78064



PG DRIVES TECHNOLOGY

A SPIRINT Company



PG DRIVES TECHNOLOGY INC
2532 East Cerritos Avenue
Anaheim
CA 92806-5627 USA
Tel: +1 (714) 712 7911
Fax: +1 (714) 978 9512
www.pgdt.com

PG DRIVES TECHNOLOGY LTD
1 Airspeed Road
Christchurch
Dorset BH23 4HD UK
Tel +44 (0) 1425 271444
Fax +44 (0) 1425 272655
www.pgdt.com

PG DRIVES TECHNOLOGY ASIA
Taiwan International Business Center
4F, 25, Sec. 1 Tunhua S. Rd.
Taipei Taiwan ROC
Tel +886 (0)2 2579 1821
Fax +886 (0)2 2579 8381
www.pgdt.com

DIMENSIONS

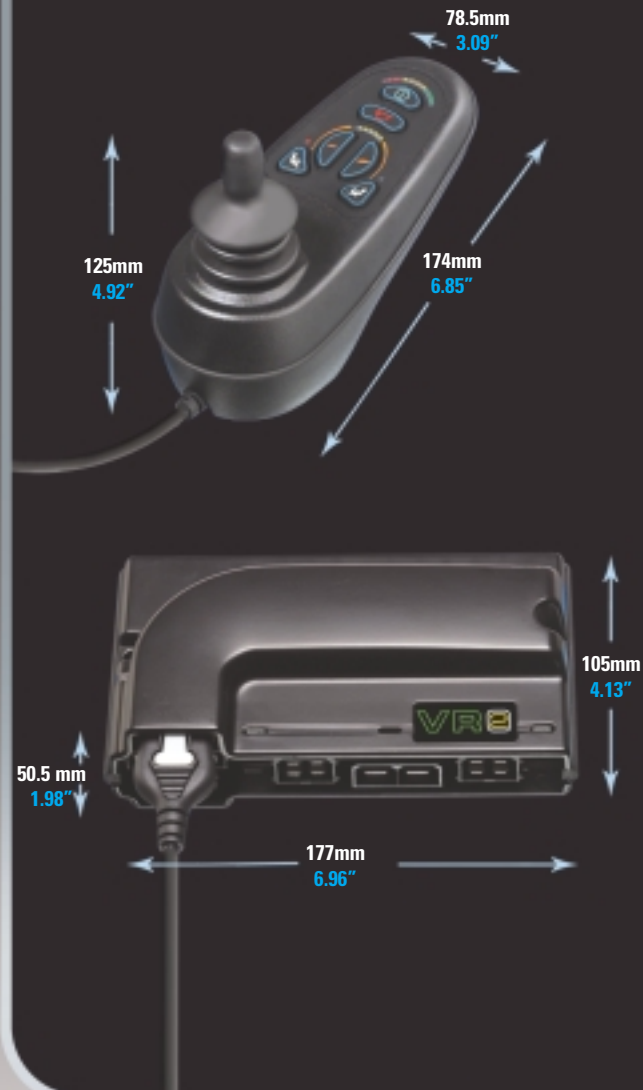

SK78064/04/05

VR2 is a trademark of PG Drives Technology Ltd. Information and specification contained within the publication may change without notice.